



RHINO REAR MAIN GUSSET or REAR BUMPER MOUNT

TOOLS NEEDED: 14mm Socket
14mm Wrench
17mm Socket
3/8" Ratchet
8mm Allen Wrench
Blue Thread Locker

PARTS INCLUDED: Welded Gusset Assembly
2 Large 10mm Washers
4 10mm x 75mm Bolts
2 10mm x 25mm Bolts
11 10mm Regular Washers
1 10mm X 30mm Hex Bolt
6 10mm Nylon Lock Nuts

To install your new Rear Main Gusset or Rear Race Bumper, you will need to raise the rear end of the car on jack stands, so the rear tires are off the ground. Remove the 4 rear a-arm mounting bolts. Position the new plate or bumper onto the rhino as shown below, and use the 4 long 10mm bolts with washers and nuts to secure it to the chassis through the rear a-arm mounts. The holes have been slotted to fit with the variances in the chassis. Leave the plate loose. Next, line up the differential mount using the 10mm fine thread hex bolt and washer. If the hole doesn't line up, it may be necessary to loosen the two upper bolts that hold the differential so you can get the new mount lined up. Once you get the bolt threaded in, tighten down the other two mounting bolts if you had to loosen them. Be careful to not over tighten the bolt that threads into the differential, because the threads are aluminum and softer than normal. We recommend using blue thread locker on that bolt to keep it from coming loose. Next, take the 2 shorter 10mm bolts with 2 regular washers, 2 large thick washers, and nuts, and position them as shown below. Once all bolts are mounted, then tighten them all to about 45 ft lbs except for the differential mount. The two hook slots can be used to secure the rhino when trailering it.

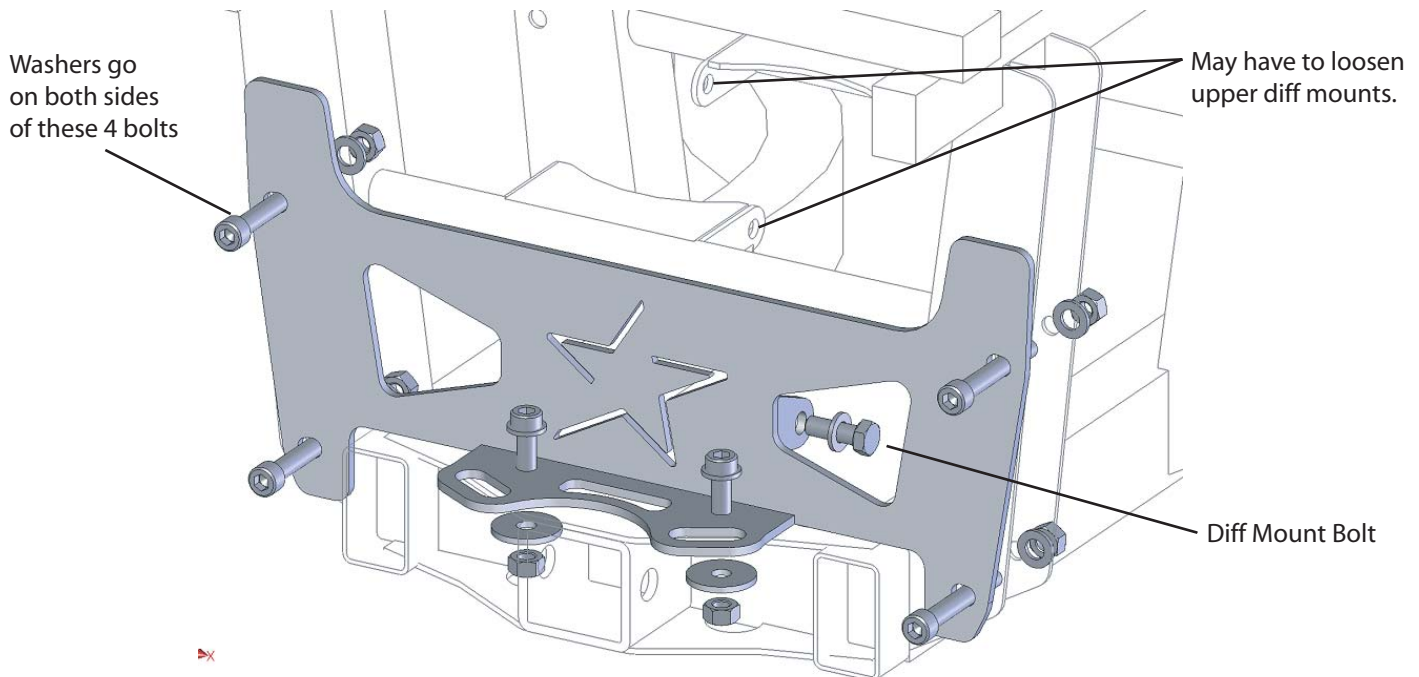

CLEANING/

You can clean this part with soap and water.

MAINTAINING:

The only maintenance required is to periodically check the bolts to make sure they are tight.